

The logo for KEYA, featuring the word "KEYA" in a stylized, white, sans-serif font. The letters are interconnected, with the 'K' and 'E' sharing a vertical stroke, and the 'Y' and 'A' sharing a vertical stroke. A registered trademark symbol (®) is located at the top right of the 'A'.

UNLOCK INNOVATION

The background features a blue gradient with decorative white lines. On the right side, several thin white lines curve upwards and outwards. At the bottom, a series of thin white lines form a wavy, horizontal pattern that curves upwards on the right side.

TRONIC CARD  
MONTAJE / ASSEMBLY



PLANTILLA CERRADURA PUERTA DERECHA  
 TEMPLATE OF RIGHT HAND DOOR

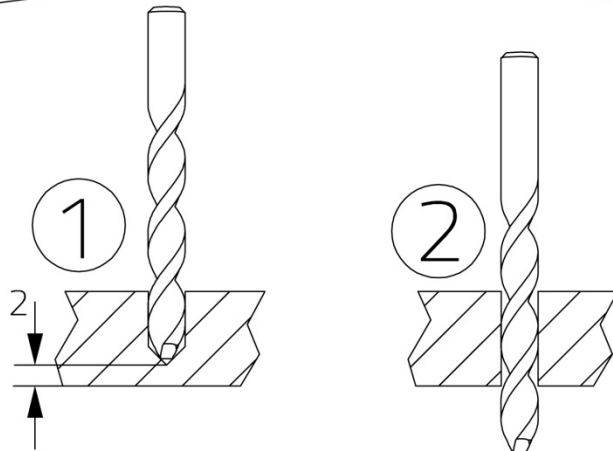
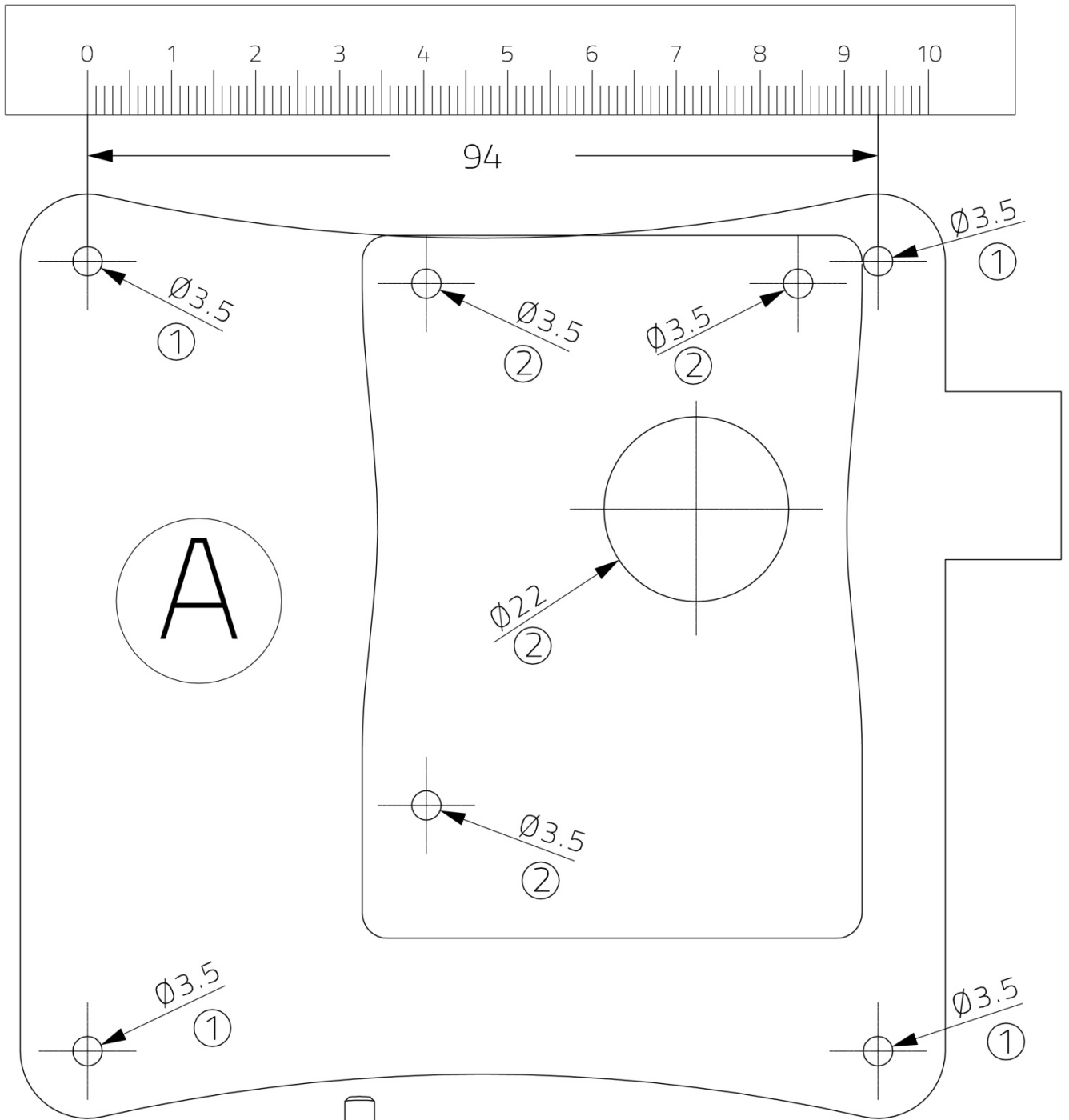

PLANTILLA CERRADURA PUERTA IZQUIERDA  
 TEMPLATE OF LEFT HAND DOOR

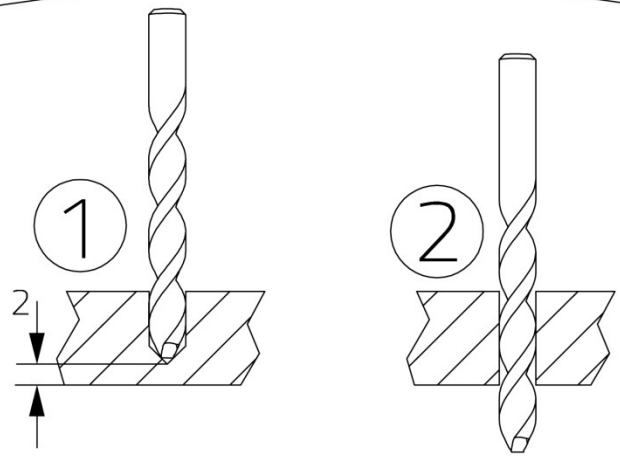
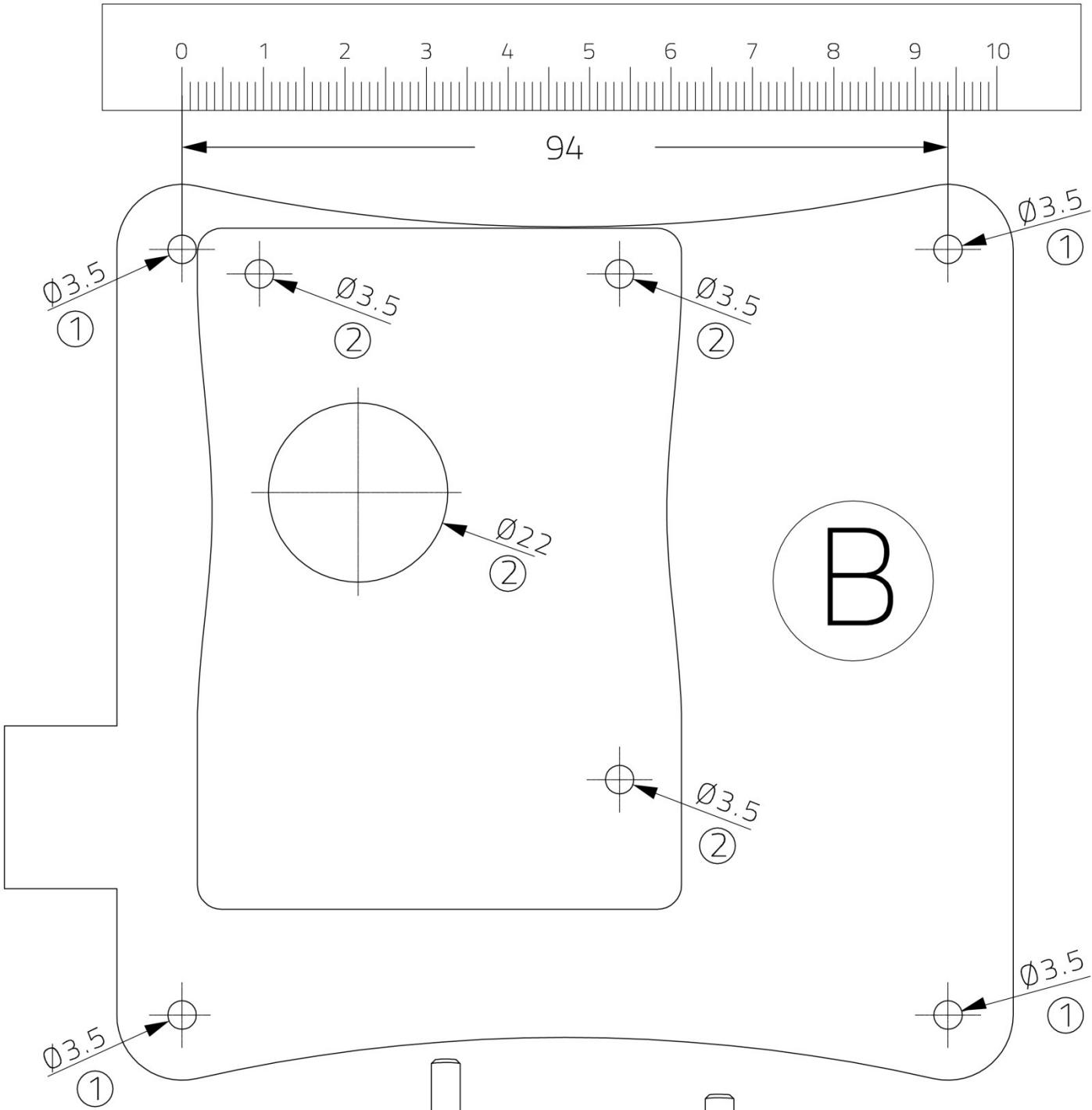

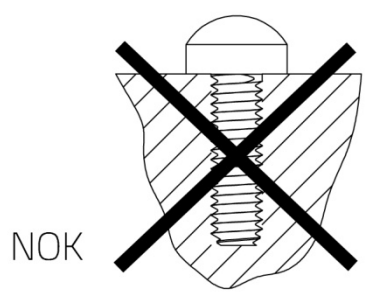
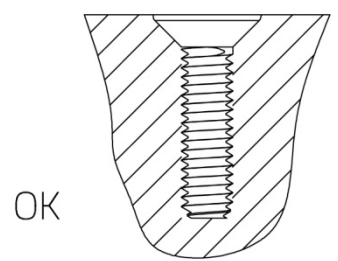
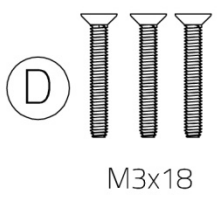
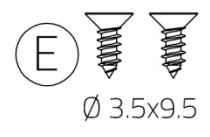
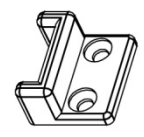
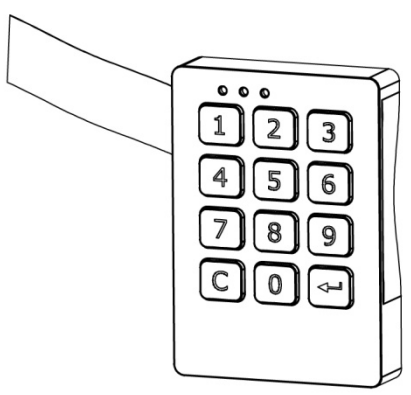
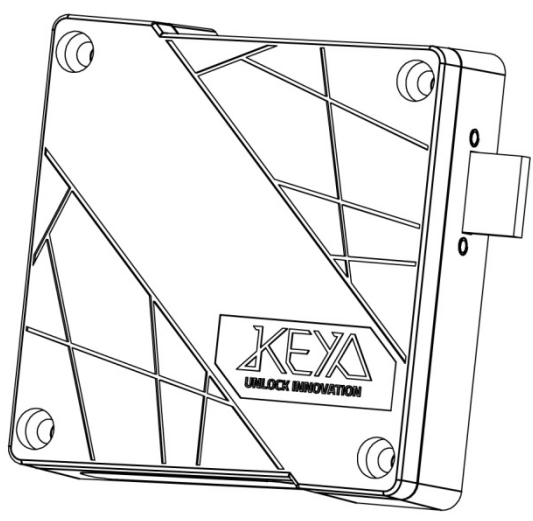

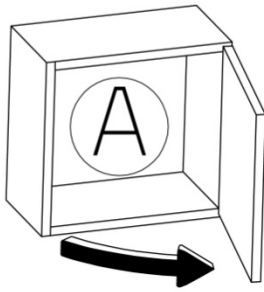

PUERTA DERECHA  
RIGHT HAND DOOR

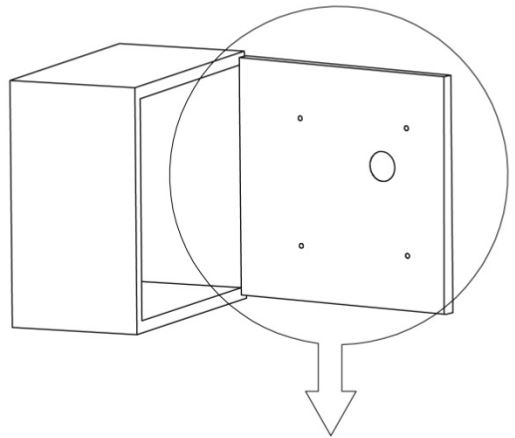

PUERTA CON MONEDERO EXISTENTE  
DOOR WITH EXISTING COIN LOCK

1

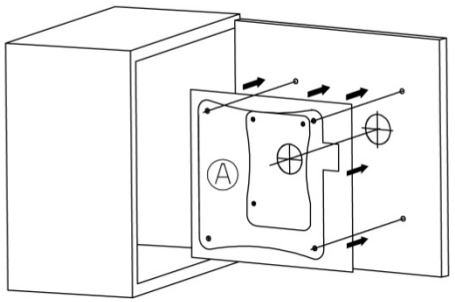

2

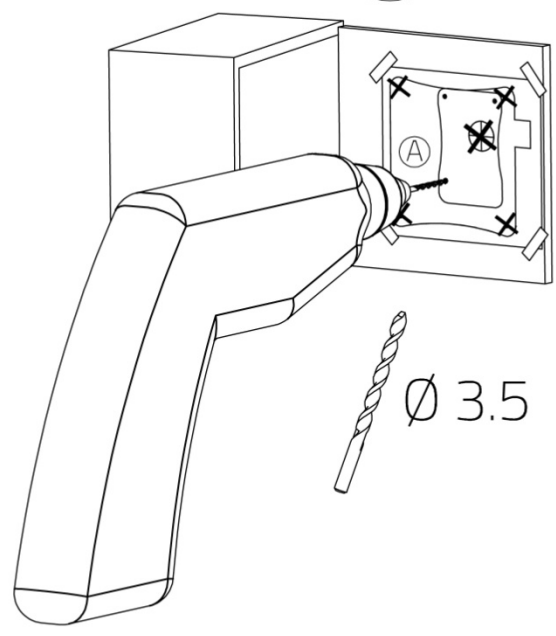

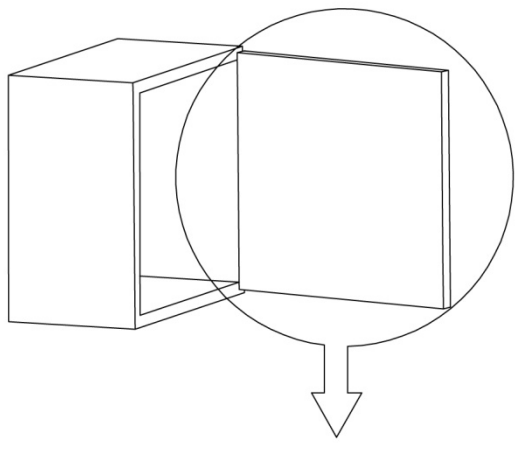

PUERTA NUEVA  
NEW DOOR

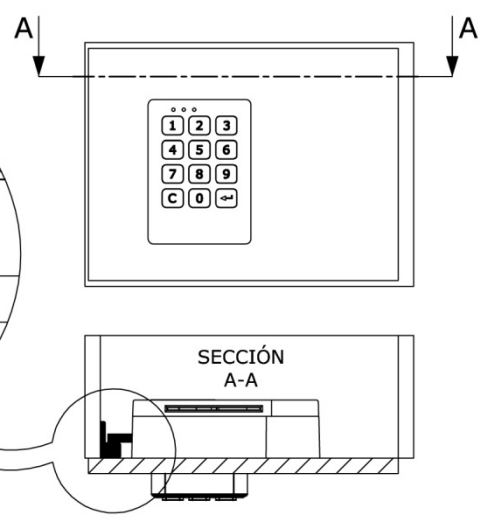
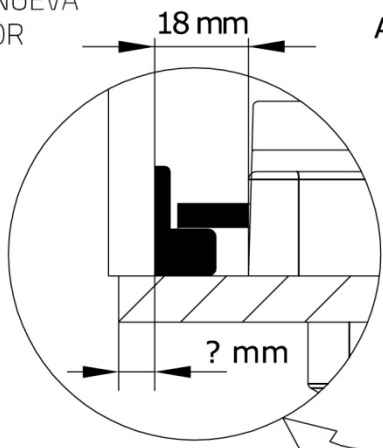

1

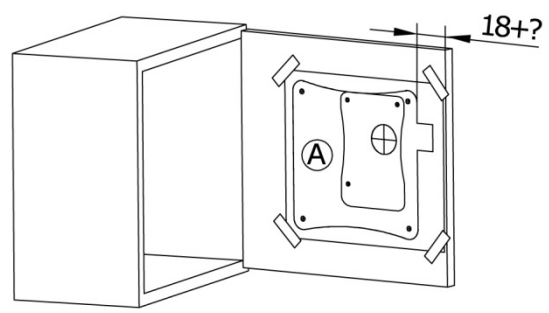

2

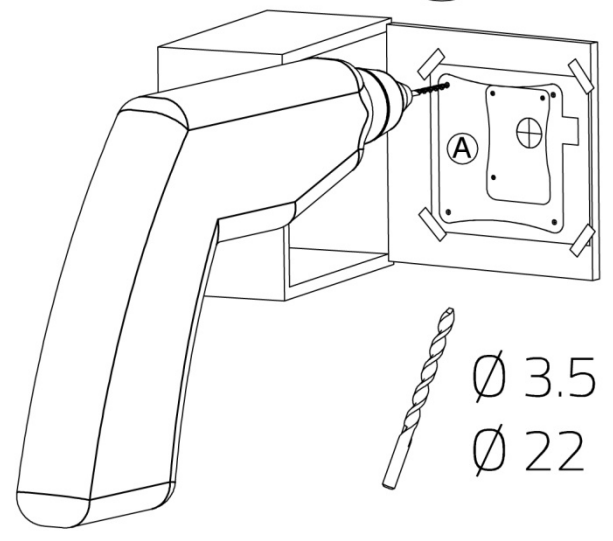

3

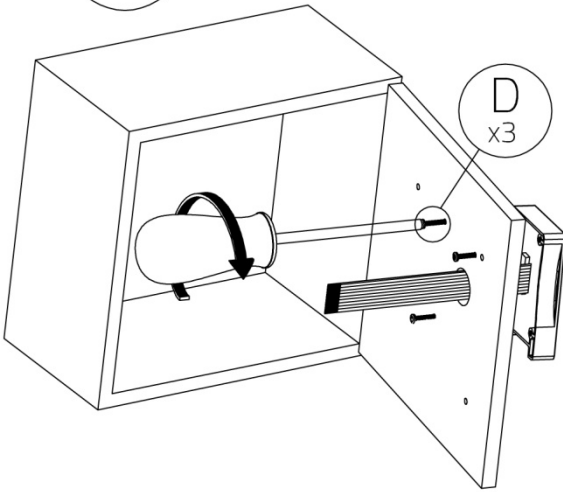

4

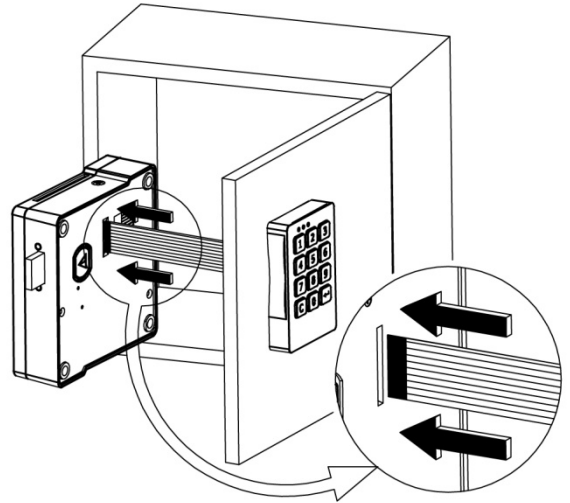

5

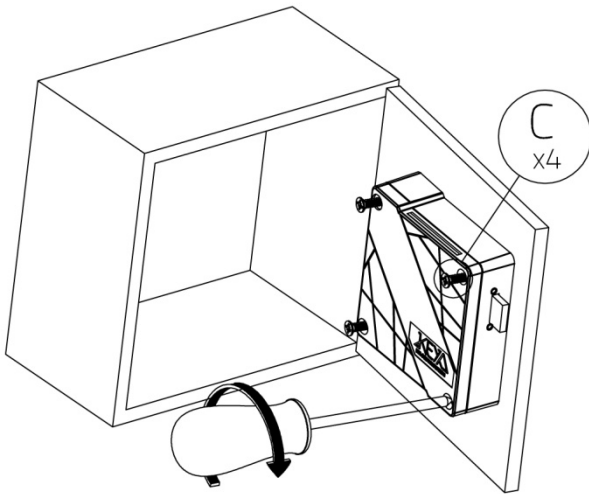

6

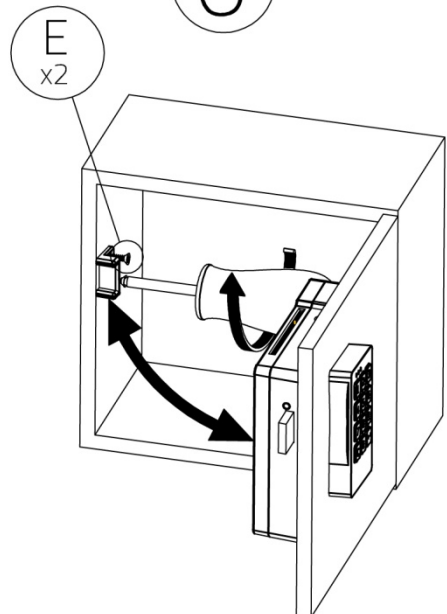



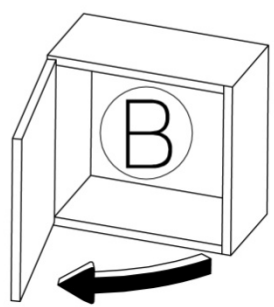

PUERTA IZQUIERDA  
LEFT HAND DOOR

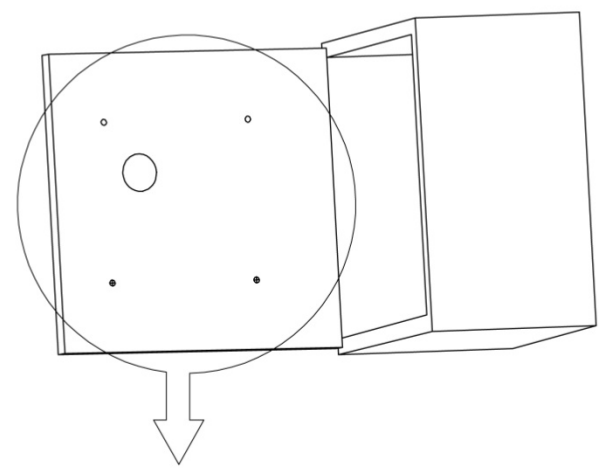

PUERTA CON MONEDERO EXISTENTE  
DOOR WITH EXISTING COIN LOCK

1

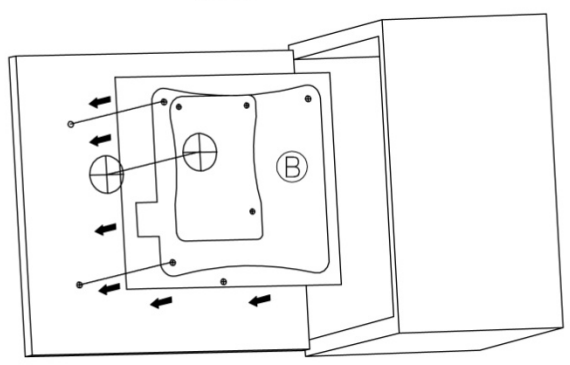

2

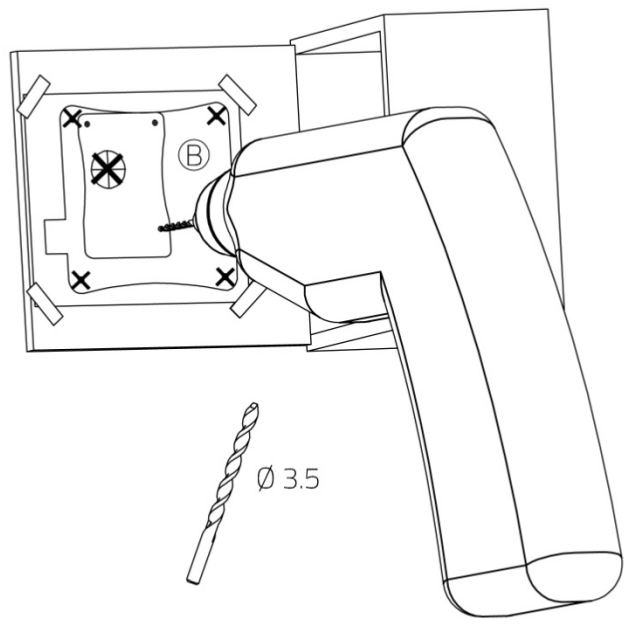

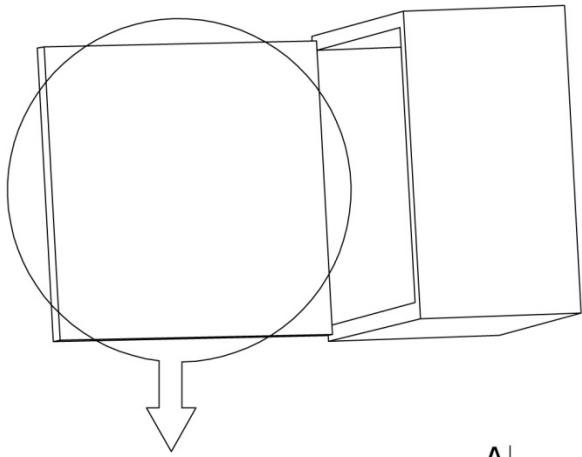

PUERTA NUEVA  
NEW DOOR

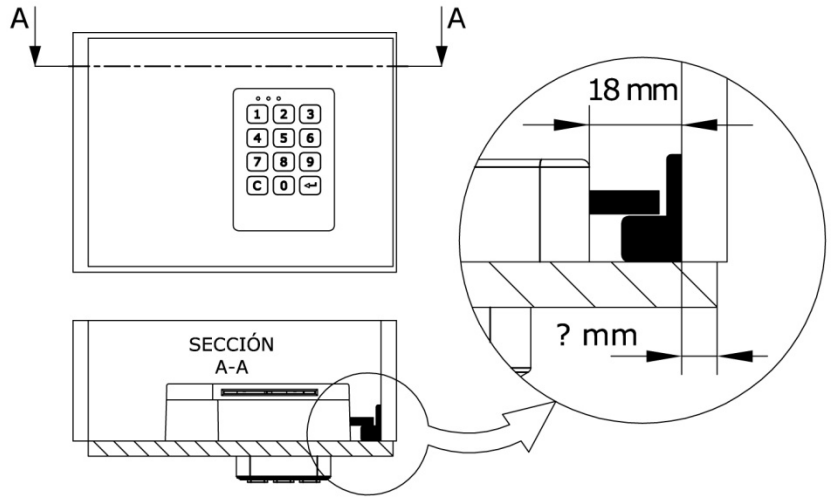

1

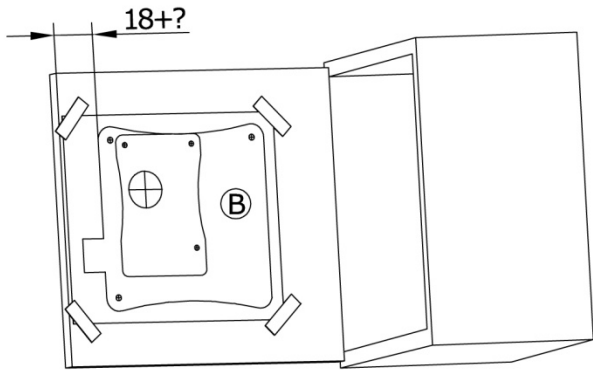

2

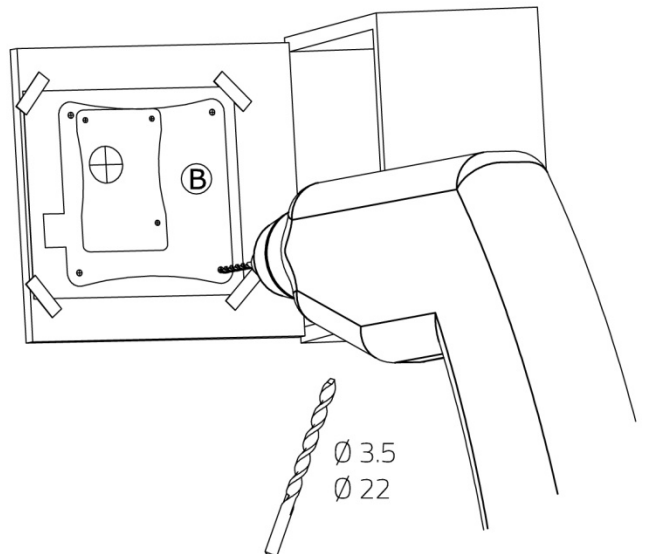

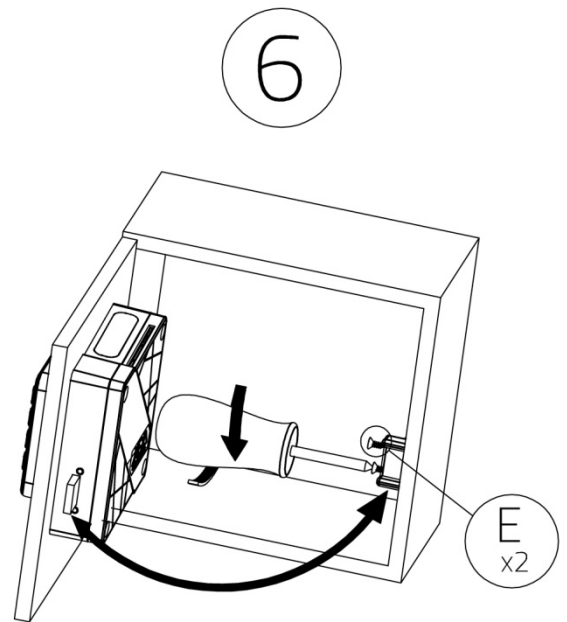
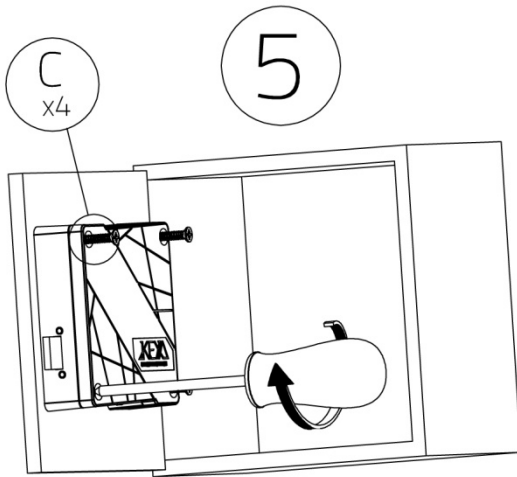
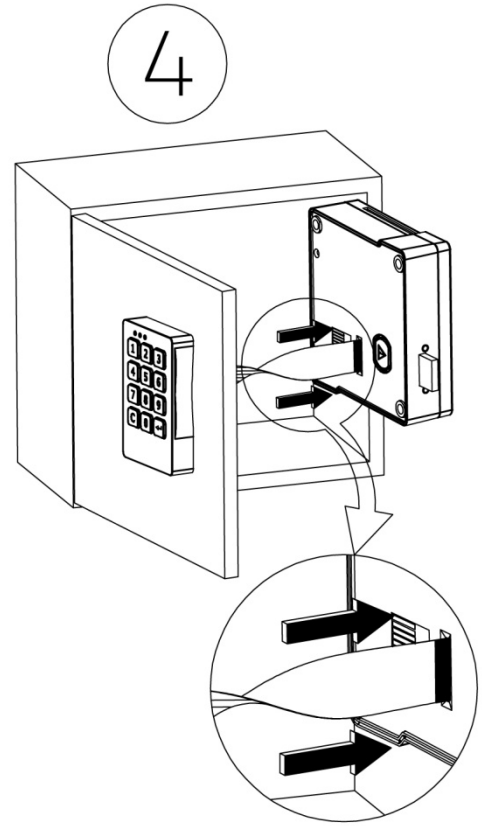
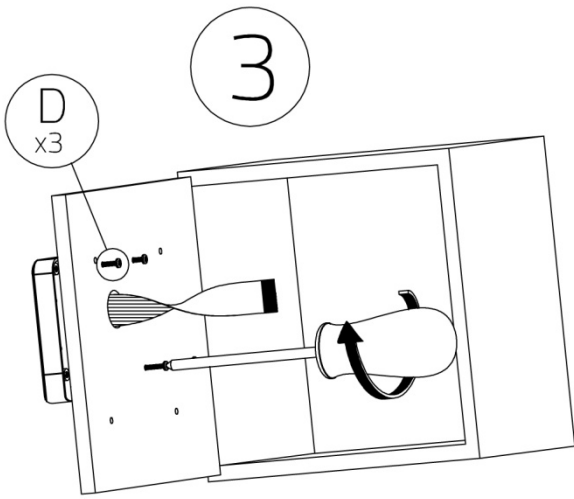

## FAQ's Preguntas más frecuentes / Frequently asked questions

Una vez instalado, al presionar las teclas, la cerradura no responde (no emite pitido ni funciona)

Once assembled, the lock does not work when the key buttons are pressed (no sound and the lock does not work)

Verificar que el cable esté correctamente conectado (recto e introducido hasta el fondo).

Verify that the cable is properly connected (straight and until the bottom).

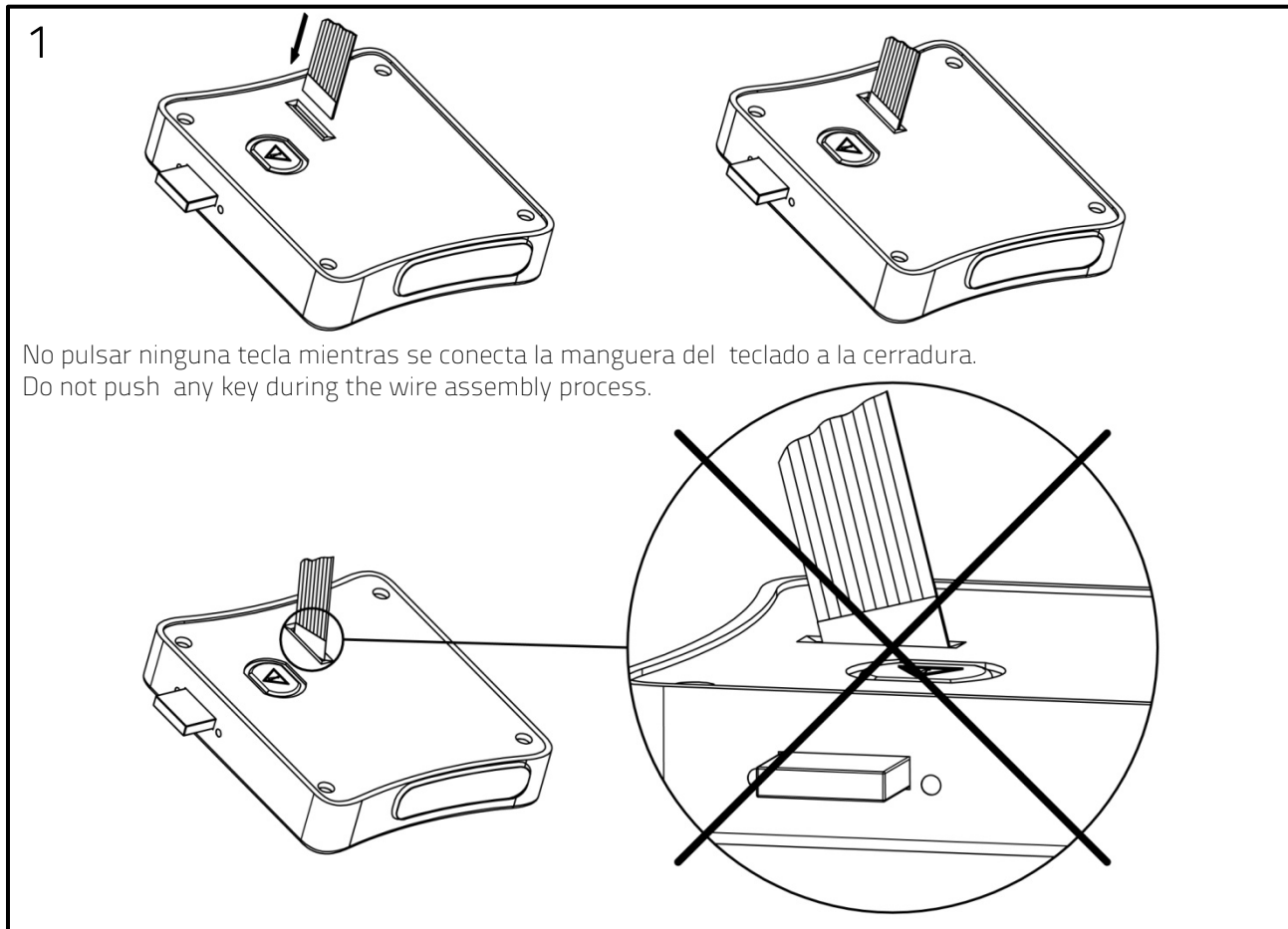

Verificar que las pilas estén en la posición correcta (respetando la polaridad indicada en el compartimento)

Verify that the batteries are in the right polarity (as indicated in the battery box).

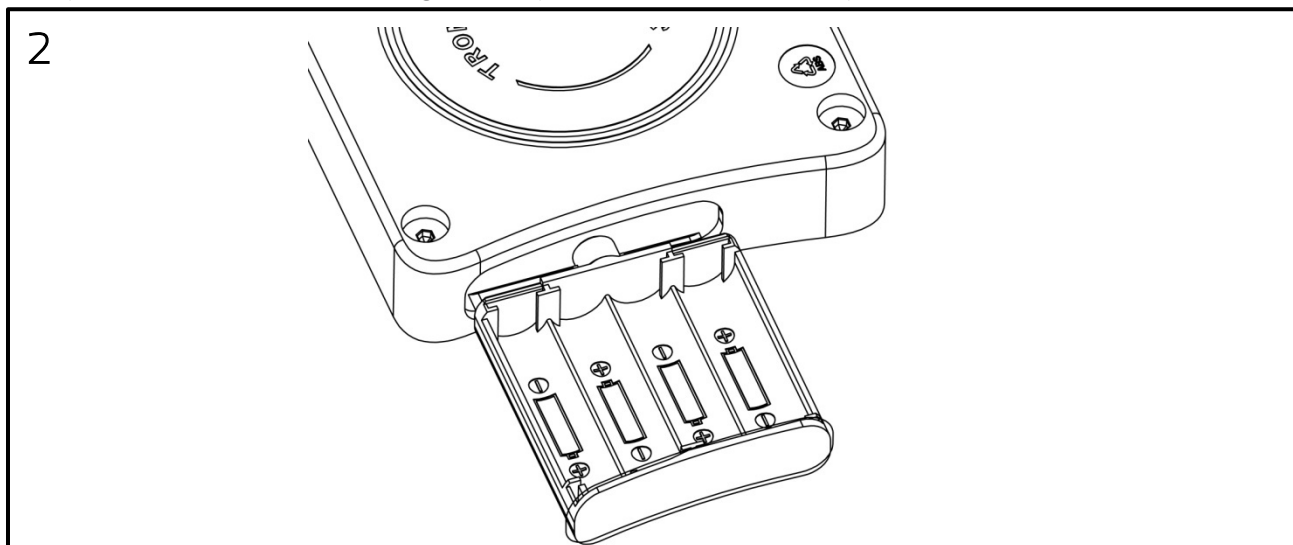

El pestillo no abre / cierra después de introducir un código válido.

The latch does not open / close after a correct code.

Verificar que los cuatro tornillos de fijación de la cerradura no estén excesivamente apretados (<20Kgf / cm2).  
Verify that the screws are not fastened too tight (<20kgf / cm2).

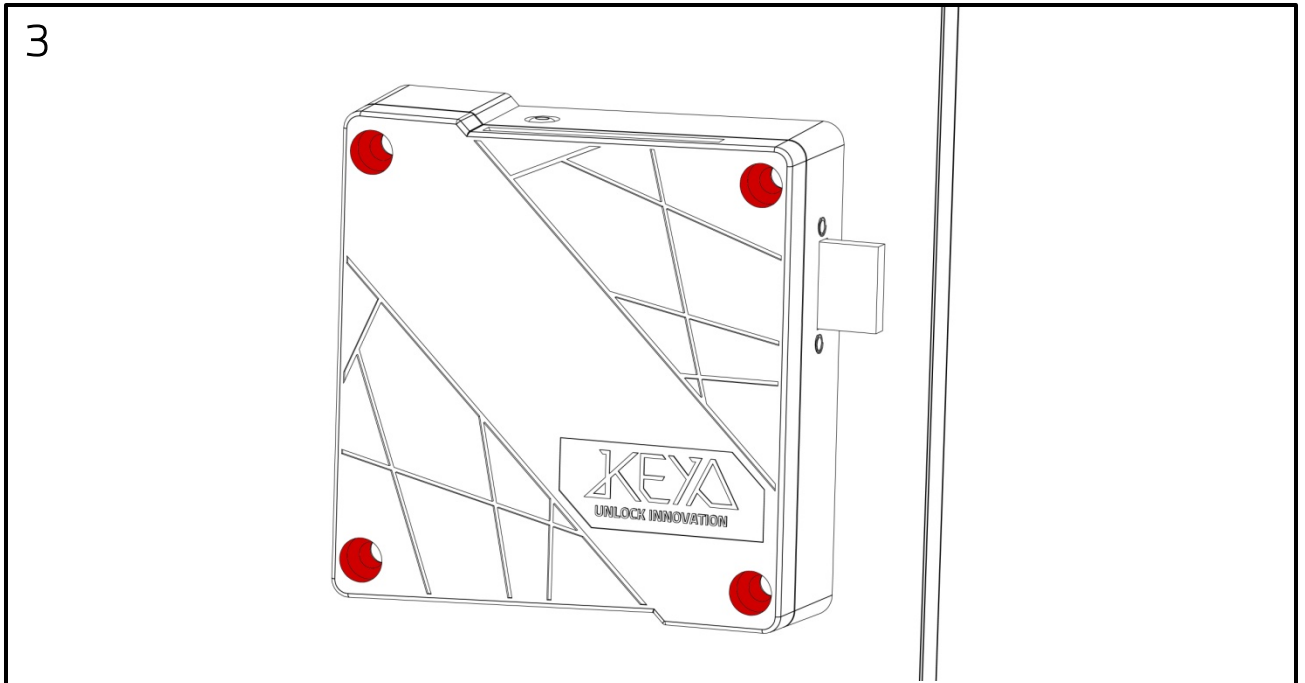

Verificar que el pestillo abre y cierra sin impedimento (roce, interferencia contra el marco)  
Verify that the latch works smoothly in and out, without any friction with the door frame.

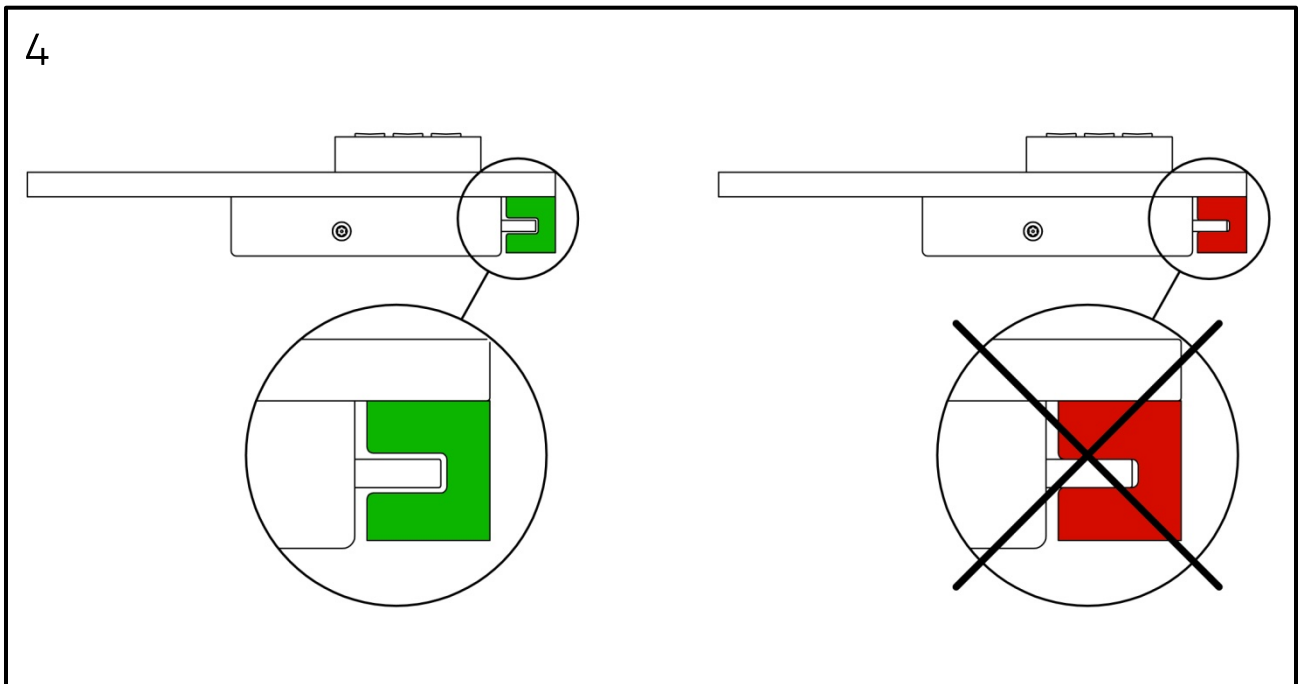

Al introducir un código válido y pulsar ENTER, destellan los tres LEDs a la vez (verde-amarillo-rojo) y la cerradura no funciona.

After introducing the correct code and pressing ENTER, the three LEDs blink at the same time (green-yellow-red) and the lock does not work.

5

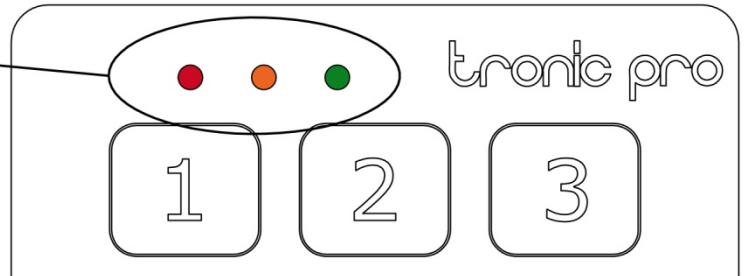
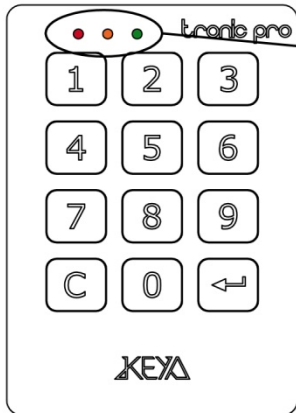

Pilas agotadas: deben ser reemplazadas.

Dead batteries: replace batteries.

Al pulsar cualquier tecla, destella el LED central (amarillo)

After pressing any button the yellow LED blinks.

6

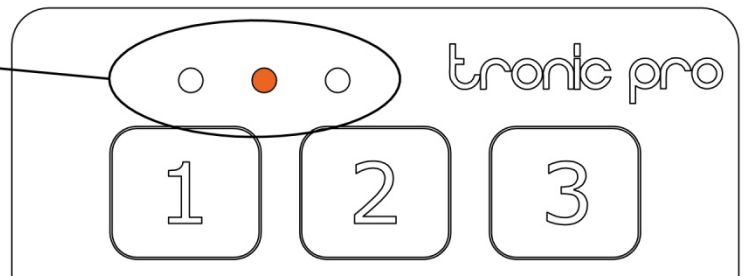
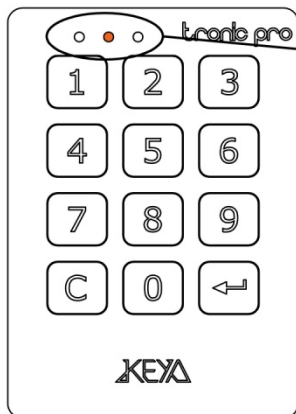

Pilas a punto de agotarse o agotadas: deben ser reemplazadas.

Dead or almost dead batteries: replace batteries.

Se han agotado las pilas con la puerta cerrada (no puedo acceder al compartimento de pilas para reemplazarlas).

The batteries are dead with the door closed (I can not access to the battery pack to replace them).

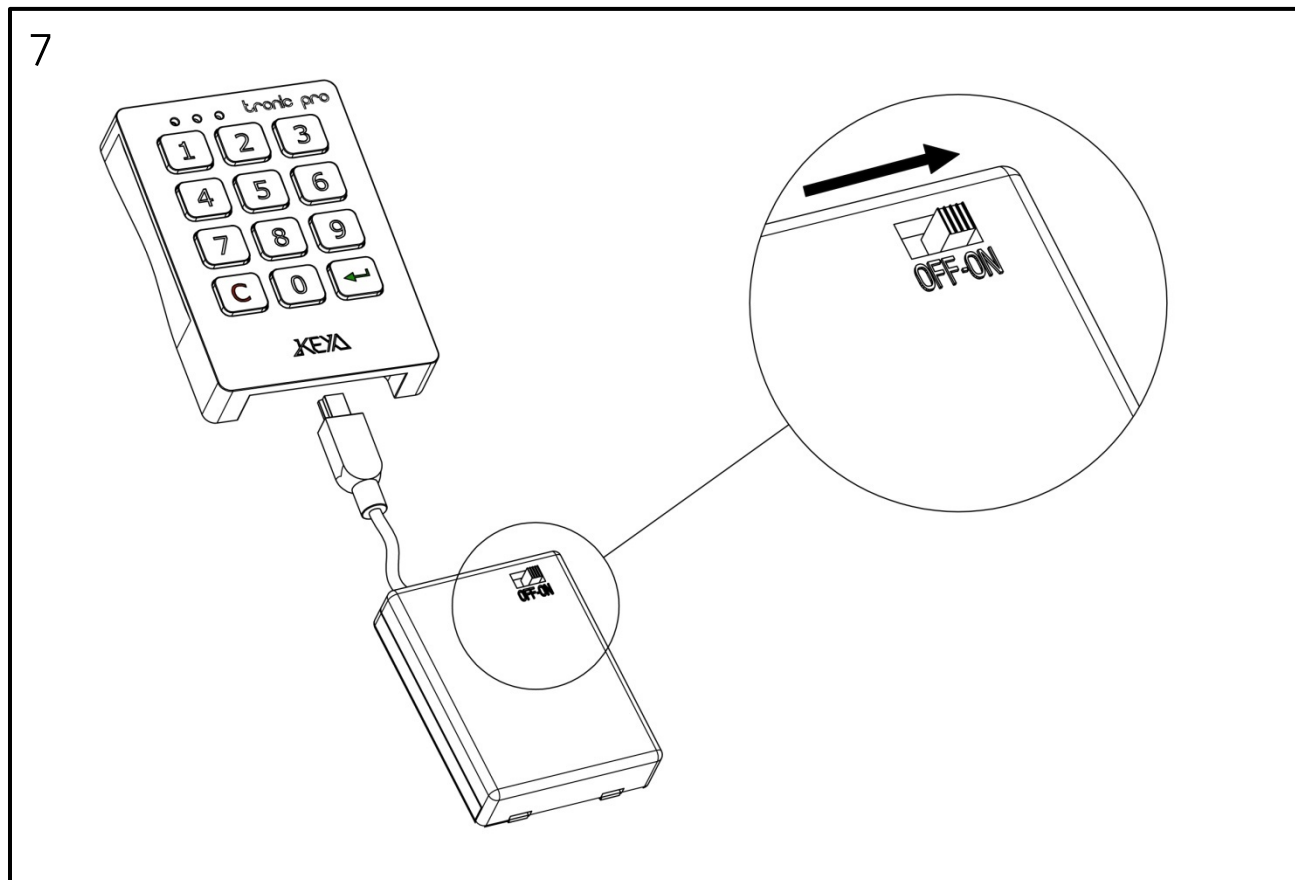

1- Conectar el BATPACK a la cerradura mediante el conector mini USB tal como se indica en la figura.  
Connect the BATPACK to the lock through the mini-USB connector, as shown in the picture.

2 - Con el BATPACK conectado (en posición ON) introducir el código de usuario (o el maestro) y abrir la cerradura.  
With the BATPACK connected (in ON position) introduce the user code (or the master one) and then open the lock.

3 - Desconectar el BATPACK y reemplazar las pilas.  
Disconnect the BATPACK and replace the old batteries for new ones.

### IMPORTANTE

Recomendamos cambiar las pilas anualmente para asegurar el buen estado de la cerradura. Las pilas tras largos periodos de tiempo instaladas, pueden dañarse y dañar la cerradura, especialmente en ambientes muy cálidos

No limpiar las cerraduras con productos de limpieza que contengan ácido clorhídrico, lejía o componentes corrosivos, especialmente en las partes metálicas.

### IMPORTANT

We suggest to change once a year the batteries for ensure their good condition. After a long time, the batteries can deteriorate and damage the lock, especially in hot environments

Do not clean the locks with cleaning products with hydrochloric acid, lye or corrosive components, especially on the metallic parts.

